

Heart Rate Monitoring Based On Electrocardiogram (ECG) Module Using IoT

Budi Santoso Wibowo¹, Putri Rahmawati Azizah²

^{1,2} Politeknik Pratama Mulia, Surakarta, Indonesia

Alamat: Jl. Haryo Panular No.18A, Panularan, Kec. Laweyan, Kota Surakarta, Jawa Tengah

Korespondensi penulis: budisanto@student.politama.ac.id

Abstract. Regular monitoring of Electrocardiogram (ECG) signals is essential for patients diagnosed with heart conditions, especially through remote systems. The Message Queue Telemetry Transport (MQTT) protocol is employed due to its ability to manage data transmission and reception based on user-defined topics. This study aims to design and implement a heart rate monitoring device using an ECG module as a sensor and ESP32 as a microcontroller, while also analyzing Quality of Service (QoS) parameters including throughput, delay, and packet loss. Data is transmitted via the internet using both Unshielded Twisted Pair (UTP) cables and wireless connections, displayed in real-time on the Ubidots website, and analyzed using Wireshark. Data collection was conducted periodically over time intervals of 30 minutes, 1 hour, 2 hours, 5 hours, 8 hours, 12 hours, 18 hours, and 23 hours. The results show varying QoS values influenced by factors such as weather conditions, internet bandwidth, and the specifications of computers and routers. The device is portable, powered by a 3000mAh battery, but its performance depends on the availability of a stable internet connection.

Keywords: ECG; MQTT; QoS.

Abstrak. Pemantauan Elektrokardiogram (EKG) secara berkala bagi pasien dengan gangguan jantung memerlukan sistem yang mampu diakses jarak jauh. Protokol Message Queue Telemetry Transport (MQTT) digunakan karena kemampuannya dalam mengatur pengiriman dan penerimaan data berbasis topik sesuai kebutuhan pengguna. Penelitian ini bertujuan untuk merancang dan mengimplementasikan sistem monitoring detak jantung berbasis MQTT, menggunakan sensor EKG dan mikrokontroler ESP32, serta menganalisis kualitas layanan (Quality of Service/QoS) melalui parameter throughput, delay, dan packet loss. Data dikirimkan melalui jaringan internet menggunakan media transmisi kabel UTP dan koneksi nirkabel, ditampilkan secara real-time melalui platform Ubidots, dan dianalisis menggunakan aplikasi Wireshark. Pengumpulan data dilakukan dalam interval waktu yang bervariasi, mulai dari 30 menit hingga 23 jam. Hasil analisis menunjukkan variasi nilai QoS yang dipengaruhi oleh faktor eksternal seperti kondisi cuaca, bandwidth internet, serta spesifikasi perangkat keras dan router. Alat ini bersifat portabel dengan kapasitas baterai 3000mAh, namun memiliki keterbatasan dalam hal ketergantungan pada koneksi internet yang stabil.

Kata kunci: EKG; MQTT; QoS;

1. INTRODUCTION

Everyone is affected by the rapid development of technology and information. This has an impact on ongoing, simple to complex developments in the field of electronics. One of these is technological advancement in the field of sensor-based networks. In terms of applications and technology, the medical field has even adopted and developed electronic technology (Wohingati & Subari, 2015). The Arduino microcontroller is frequently used, particularly in monitoring and measuring. An electrocardiogram, a measurement of the electrical activity of the heart, is typically performed during the medical examination stage (ECG). The doctor will learn about the patient's heart condition from the ECG process of heart signals. The ECG test is required to help diagnose the patient's heart condition, regardless of whether the electricity is

normal or not (Madona & Fadilla, 2021). A regular ECG is also required to check on patients who have been given a diagnosis of heart disease. Real-time and long-term (24-hour) heart rate monitoring is possible with a wireless electrocardiogram (ECG) (Hasibuan & Mulyadi, 2018).

Sudden cardiac death is defined as an unexpected death that occurs without prior trauma within a short period of time, usually less than an hour from the onset of symptoms. Symptoms appear when the heart's normal rhythm is disrupted and the heart begins to beat erratically, causing the heart to lose its ability to effectively pump blood to the brain (Ponikowski et al., 2014). The brain dies within ten minutes, and the patient can no longer be helped. When a heart patient who is alone at home has a heart attack and cannot be helped (Nadia, 2018).

The research "Heart Rate Monitoring System Using Sensor AD8232 Based on the Internet of Things" by Ria Hariri, Lutfi Hakim, and Riska Fita Lestari (2019), Engineering Electrical Students from the University of PGRI Banyuwangi, is previous research associated with the subject of discussion and used as the basis for conducting research (Ria Hariri et al., 2020a). This research aims to propose a system design for monitoring heart rate activity at a lower cost using the AD8232 sensor using the NodeMCU ESP8266 module that supports the Internet of Things (IoT) system. According to the results of this test, the results of calibrating the device using an ECG simulator from the Blambangan Regional General Hospital (RSUD) show an error percentage of 1.7%. Furthermore, the average percentage error between measurements when using the proposed system with medical devices was 1.21%. This result demonstrates that the proposed system has a very low level of error. The measurement results were successfully monitored using a web application developed on an Android or a browser application on a personal computer. Because it is based on the internet of things, this demonstrates that monitoring heart conditions can be done anywhere and at any time in real time (Ria Hariri et al., 2020b).

Based on the above problems and previous research, a research on "Human Heart Rate Monitoring Tool by Utilizing IoT-Based Electrocardiogram (ECG) Module" was made.

2. LITERATURE STUDY

Bagian ini menguraikan teori-teori relevan yang mendasari topik penelitian dan memberikan ulasan tentang beberapa penelitian sebelumnya yang relevan dan memberikan acuan serta landasan bagi penelitian ini dilakukan. Jika ada hipotesis, bisa dinyatakan tidak tersurat dan tidak harus dalam kalimat tanya. The most important physiological parameter that can provide a precise assessment of cardiac function is an ECG, which depicts the electrical activity of the heart (Sarmah, 2020). The ECG is a graphical representation of the electrical activity of the heart that is used for clinical diagnosis. ECG is frequently used to diagnose cardiovascular disorders. The electrical activity of the heart is caused by changes in ions, which can be measured by placing electrodes on the skin's surface. The electrical potential records produced by the heartbeat are also represented graphically by an ECG. There are two ECG signals: the P wave, which occurs due to atrial muscle contraction, and the QRS wave, which also occurs due to atrial muscle contraction but also occurs due to thick ventricular muscle contraction, so the QRS wave is quite high (Pan & Tompkins, 1985)

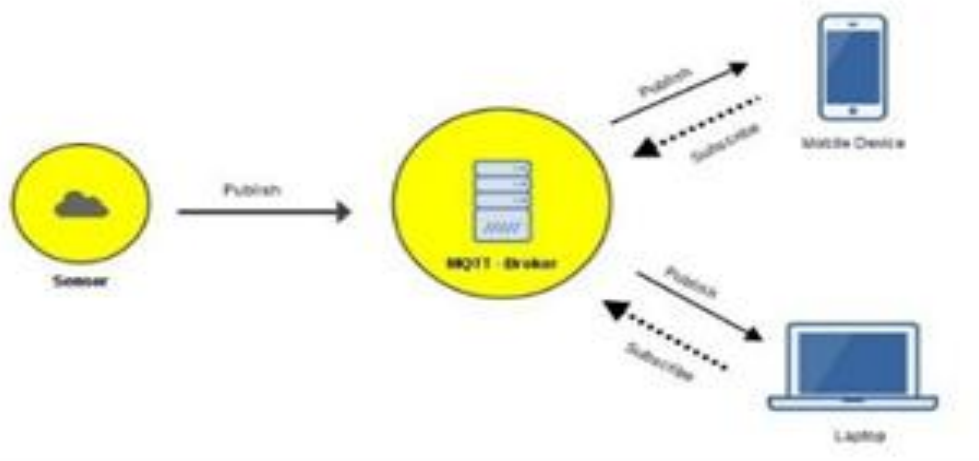

Figure 1 MQTT System

The MQTT protocol is an openly designed and simple to implement publish/subscribe architecture that can handle thousands of remote clients with a single server(Saputra et al., 2017). MQTT reduces the need for network bandwidth and device resources. MQTT is used for data transmission by these IoT devices because it is simple

to implement and efficiently communicates IoT data. MQTT allows for messaging from device to cloud as well as cloud to device .

The general MQTT system depicted in Figure 1 requires two major software components: the MQTT client, which will be installed on the device (Arduino uses the pubsubclient library), and the MQTT broker, which will handle publish and subscribe data. MQTT brokers are already available on the web service platform that will be used. The MQTT client, MQTT broker, publish in MQTT, and subscribe in MQTT are all MQTT components (Nurfiqin, 2020).

Table 1. Quality of Service Level 1 (Toldinas et al., 2019)

<i>Sender action</i>	<i>Control packet</i>	<i>Receiver A</i>
<i>Store message</i>		
<i>Send PUBLISH QoS 1, DUP 0, <Packet Identifier></i>	----->	
		<i>Initiate onward delivery of the application message</i>
	←-----	<i>Send PUBACK <Packet identifier></i>
<i>Discard message</i>		

This research uses a level 1 QoS classification for calculations on throughput, packet loss, and delay. Service at QoS level one guarantees delivery of the message at least once to the message recipient. The sender keeps the message until it receives a PUBACK packet from the message receiver's acknowledgement. In Table 1, information related to quality of service (QoS) level one is presented (Saputra et al., 2017).

3. METHODS

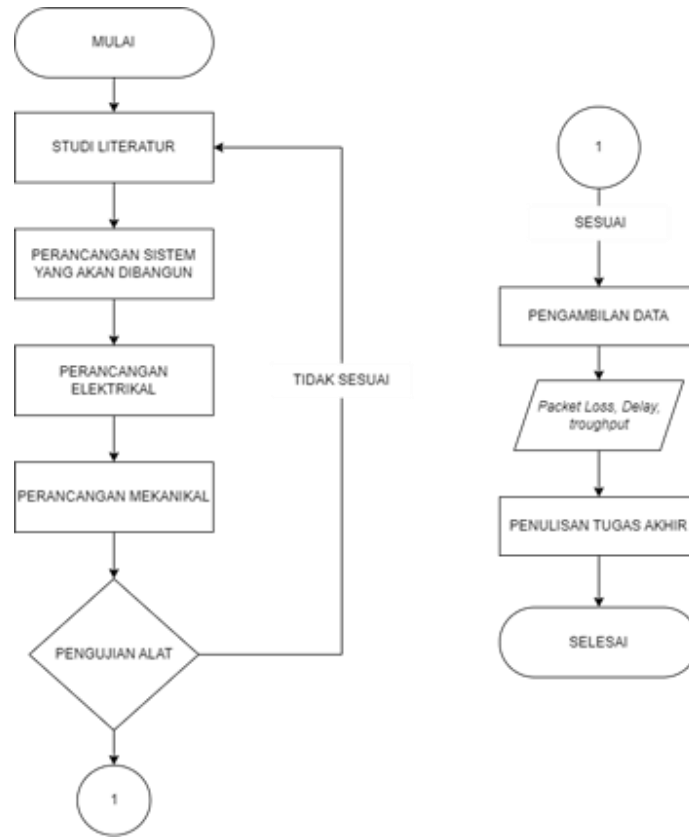

Figure 2 Flowchart of Research Design

Figure 2 explains the stages of the research. The research stages begin with a literature study to find and study the analysis methods that will be used for this research. After obtaining and studying the methods carried out, then proceed to design the system to be built and proceed with the electrical design and then testing the tool. If the test is successful, then proceed with the data collection stage to be written in the final project report, if it is not successful, troubleshooting is carried out and conducting a literature study again.

Figure 4 above is the electrical design of the human heart rate monitoring device by utilizing the IoT-based ECG module. The components consist of two series of 18650 batteries, with specifications of 3000 mAh battery capacity and 7.4v voltage which serves to provide power supply support from the components used. Then, the micro SD module functions to write and store offline data read by the sensor, the 2S charger module is used as a battery charging component and disconnects the current when there is a short circuit or short circuit in the battery. Then the adapter jack for charging batteries with 9V 2A adapter specifications. Then the button functions as a start and stop button for the sensor to read, the ESP32 microcontroller is used to control the components used such as sensors, micro SD, start and stop buttons, ADS1293 functions as a sensor to read the output in the form of ECG signals and step down which has a DC 5V specification which functions to reduce the voltage from the battery so that it can be received properly, so as not to damage other components, and the resistor is a component used to inhibit or inhibit the ECG signal reduce the voltage that has been supplied. LED as an indicator of the tool that the tool is ready for use and the on/off switch is used to cut off the supply.

The electrical design of the tool has a workflow, namely when the switch is turned on in the on condition, the component has been supplied with current from the battery whose voltage has been reduced by the step down and then the LED indicator is on. A live LED indicates that the component has been supplied properly. Then, when the battery weakens the LED starts to dim, then the battery can be charged through the adapter jack that has been attached to the component. The current that delivered by the adapter is received by the charger module 2s, slowly charging the battery).

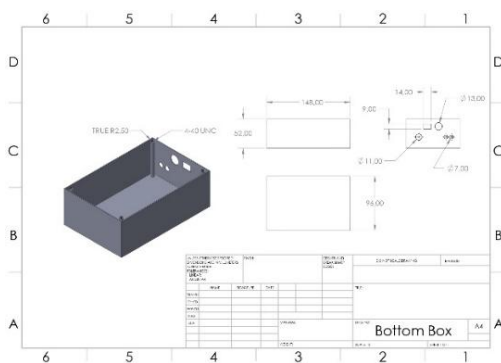

Figure 6 Mechanical Design of Bottom Box

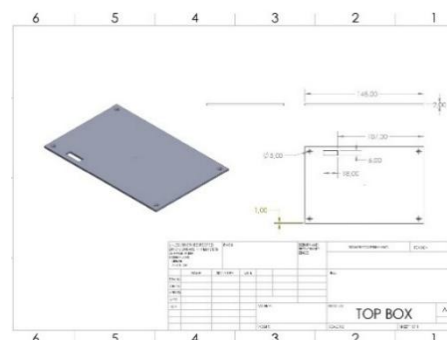

Figure 7 Mechanical Design of Top Box

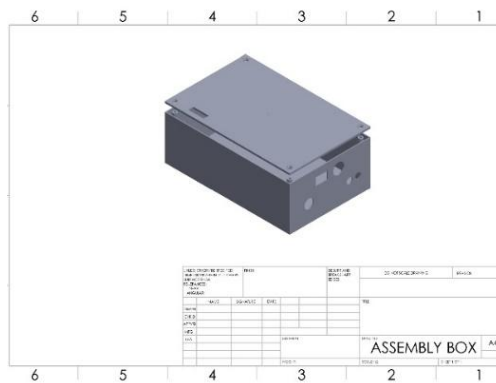

Figure 8 Mechanical Design of Assembly Box

Mechanical design can be seen from Figure 6, Figure 7, and Figure 8 which has a box or case function that serves as a protector and to avoid components from unwanted touches, which can cause damage. The box or case has a length of 148 mm and a width of 96 mm with a height of 52 mm, the box is 2 mm thick, and several holes for the power adapter, turn on/off switch, start/stop switch, micro SD and two holes for channel 1 (one) and channel 2 (two). Each hole has a different size, the adapter hole has a diameter of 11 (eleven) mm, the turn on/off switch has a hole size of 14 (fourteen) mm long and 4 (four) mm wide, the start/stop switch hole has a diameter of 13 (thirteen) mm, the micro SD hole has a size of 18 (eighteen) mm long and 6 (six) mm wide and two holes for channel 1 (one) and channel 2 (two) have a diameter of 7 (seven) mm

Tests were carried out using the bandwidth specifications of UTP and Wireless internet transmission media as follows.

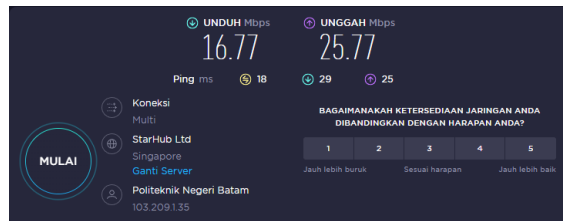
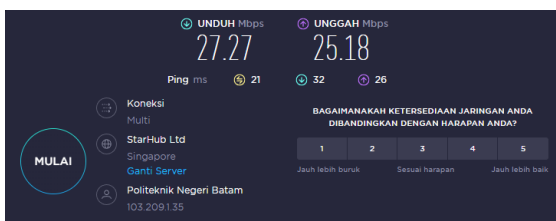

Figure 9 Bandwith of UTP Transmission Media Figure 10 Bandwith of Media Transmission Wireless

Figure 10 displays the bandwidth specifications of UTP internet transmission media having an upload power of 25.18 mbps and a download power of 27.27 mbps, using the Batam State Polytechnic's router connection. In Figure 9 bandwidth specification of wireless internet transmission media has an upload power of 25.77 mbps and a download power of 16.77 mbps, using the Batam State Polytechnic's router connection.

4. RESULT AND EXPLANATION

Tool Design Realization Results



Figure 11 Realization View of Heart Rate Monitoring Tool Using the ECG Module

Figure 11 is a picture of the realization of the mechanical design of the heart rate monitoring device using the IoT-based ECG module along with all supporting components installed in the black box. The black box is made of plastic material which has an overall size of 14.6 cm x 9.5 cm x 5.2 cm. Each hole has a function for the 9v adapter, power on/off, start/stop, channel 1 (one) and channel 2 (two), led indicator, and micro SD card.



Figure 12 Monitor/Record



Figure 13 Idle Mode

In Figure 12 is a condition when the device starts recording and sending data to the website and Figure 13 is a condition when the device is not recording or in iddle mode where this condition does not receive or send data.

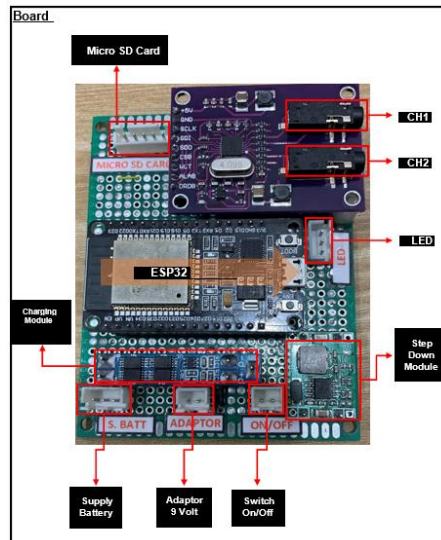

Figure 14 Electrical Board

Figure 14 is the realization of the previously designed electrical design consisting of esp32, micro sd card, charging module, battery supply, 9v adapter, on/off switch, LED, ADS1293 sensor, and step down module.

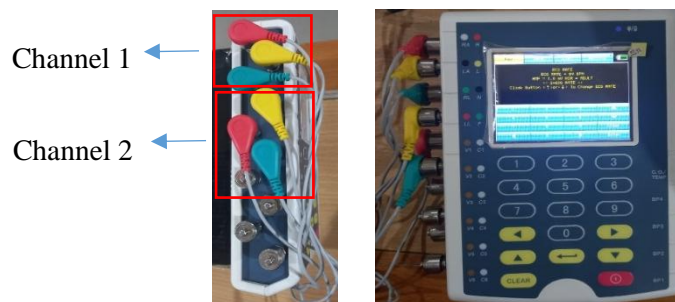
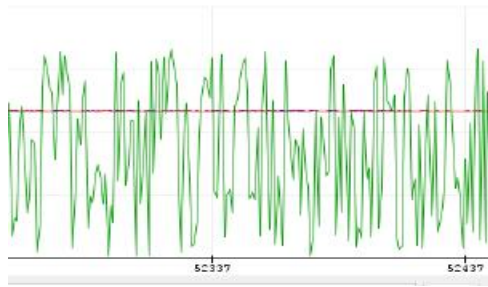

Figure 15 Electrode Placement on the Simulator

In Figure 15 is the placement of electrodes on the simulator that will be used for sensor calibration and distributing ECG signals, 6 (six) electrodes and simulators used in this study to simulate ECG signals on the heart, channel 1 (one) is placed on ports RA, LA, and RL. Then channel 2 (two) is placed on ports LL, V1, and V2. The usefulness of the port in the simulator is as an alternative to the point where the body will be monitored.

Research Result Data

In the research work there are 2 (two) stages, the initial stage of the research is to conduct sensor calibration testing which aims to test the sensor so that it can be used and receive signals distributed by the simulator properly. The next stage is to test the communication with the broker that will be used with different transmission media. The following are the testing stages.



Sensor Calibration Testing

Figure 17 ECG Signal Observation Before Sensor Calibration



Figure 16 ECG Signal Observation After Sensor Calibration

Figure 17 is an image of the sensor that is still not connected to the simulator, so there is noise generated. Then, Figure 16 is the result of observing the ECG signal generated by the simulator using the arduino serial plotter display. Based on testing before and after calibration, the results obtained are that the sensor can receive signals sent by the simulator and can be displayed offline on the plotter display owned by the arduino IDE feature, after the validation stage, the sensor can be used with the simulator

Communication Testing

Communication testing is carried out periodically with different internet transmission media infrastructure with a laptop as a monitor. Then the observation and analysis of QoS parameters by the data sent from the microcontroller connected to the internet to the broker with the parameters of delay, packet loss, and throughput. The test scenario consists of 2 (two) with different internet network transmission media used. The following is a Table 3 of test scenario:

Table 1 Communication Testing

Scenario	Internet Transmission Media	Website	Parameter
1	<i>UTP Cable</i>	<i>Ubidots</i>	<i>Delay, packet loss, throughput</i>
2	<i>Wireless</i>	<i>Ubidots</i>	<i>Delay, packet loss, throughput</i>

In scenarios 1 (one) and 2 (two), tests were carried out by sending data using different internet transmission media. Observation during testing is done using a wireshark software, from the test results, the results of quality of service delay, packet loss, and throughput are obtained.

Scenario 1 (one)



Figure 18 ECG Signal Observation Scenario 1 (one)

In this scenario, tests are carried out with different time durations, using a laptop as a monitor, the transmission medium used is an unshield twisted pair (UTP) internet cable and the ubidots website as a broker to observe and analyze the parameters of delay, packet loss, and throughput. The following is a display of the ECG signal observation with scenario 1 (one) in Figure 18.

Scenario 2 (two)

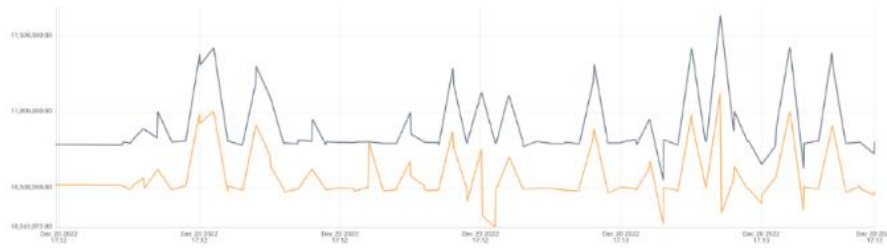

Figure 19 ECG Signal Observatin Scenario 2 (two)

In scenario 2 (two), testing is carried out with a different time duration, using a laptop as a monitor and the transmission media used is wireless internet and the ubidots website as a broker to measure delay, packet loss, and throughput parameters. The following is a display of the ECG signal observation with scenario 1 (one) in Figure 19.

Delay Calculation Analysis

```

0.257162 169.53.160.41 192.168.1.101 TLSv1.2 398 Application Data
0.257196 192.168.1.101 169.53.160.41 TCP 54 55655 → 443 [ACK] Seq=1 Ack=528 Win=511 Len=0
0.281000 192.168.1.101 13.227.254.42 TCP 55 55661 → 443 [ACK] Seq=1 Ack=1 Win=517 Len=1 [TCP segment of a reassembled PDU]
0.290100 13.227.254.42 192.168.1.101 TCP 66 443 → 55661 [ACK] Seq=1 Ack=2 Win=137 Len=0 SLE=1 SRE=2
0.786240 192.168.1.105 224.0.0.251 MDNS 95 Standard query response 0x0000 A, cache flush 192.168.1.105
1.234489 169.53.160.41 192.168.1.101 TLSv1.2 238 Application Data
1.250387 169.53.160.41 192.168.1.101 TLSv1.2 236 Application Data
1.250452 192.168.1.101 169.53.160.41 TCP 54 55655 → 443 [ACK] Seq=1 Ack=894 Win=517 Len=0
1.251869 169.53.160.41 192.168.1.101 TLSv1.2 237 Application Data
1.307286 192.168.1.101 169.53.160.41 TCP 54 55655 → 443 [ACK] Seq=1 Ack=1077 Win=516 Len=0
1.323268 192.168.1.101 52.20.239.56 TCP 55 55667 → 443 [ACK] Seq=1 Ack=1 Win=517 Len=1 [TCP segment of a reassembled PDU]
1.354418 192.168.1.101 52.20.239.56 TCP 55 55666 → 443 [ACK] Seq=1 Ack=1 Win=513 Len=1 [TCP segment of a reassembled PDU]
1.582074 52.20.239.56 192.168.1.101 TCP 66 443 → 55667 [ACK] Seq=1 Ack=2 Win=110 Len=0 SLE=1 SRE=2
1.594303 192.168.1.101 35.190.25.25 TCP 55 55668 → 443 [ACK] Seq=1 Ack=1 Win=512 Len=1 [TCP segment of a reassembled PDU]
1.603344 52.20.239.56 192.168.1.101 TCP 66 443 → 55666 [ACK] Seq=1 Ack=2 Win=114 Len=0 SLE=1 SRE=2
1.603374 35.190.25.25 192.168.1.101 TCP 66 443 → 55668 [ACK] Seq=1 Ack=2 Win=270 Len=0 SLE=1 SRE=2
1.860101 192.168.1.101 169.53.160.41 TLSv1.2 83 Application Data
    
```

Figure 20 Delay Data Capture on Wireshark Software

Delay is the time delay for packets to arrive at the client or host until they are finished being transmitted. From the test result in Figure 20, the packets received from the server to the client are obtained.

Table 2 Delay Categories Index

Media transmission	Time Testing	Delay (ms)	Index	Categories delay
UTP	30 minutes	1.46	4	Excellent
	1 hours	134.86	4	Excellent
	2 hours	126.51	4	Excellent
	5 hours	23.20	4	Excellent
	8 hours 6 minutes	81.67	4	Excellent
	12 hours	53.97	4	Excellent
	18 hours	214.90	3	Good
	23 hours 34 minutes	260505.05	1	Bad

Media transmission	Time Testing	Delay (ms)	Index	Categories delay
Wireless	30 minutes	49.33	4	Excellent
	1 hours	122.44	4	Excellent
	2 hours	179.17	3	Good
	5 hours	147.94	4	Excellent
	8 hours 27 minutes	107.647078	4	Excellent
	12 hours 7 minutes	80.754086	4	Excellent
	18 hours	126.10	4	Excellent
	22 hours 6 minutes	120.721149	1	Bad

Delay is highly dependent on the internet connection which is affected by the network hardware, the internet router between the computer and the server. Data packets going through the router will experience a delay of several milliseconds. If the delay increases, this is due to the distance between the monitor device and the access point or switch which is quite far. This applies to the use of monitoring using wireless, due to signal obstruction by walls or other objects. The more obstacles or walls that are passed, the more the wifi delay will increase. Materials such as wood, zinc, or walls can become obstacles to wifi signals. Likewise, using UTP transmission media, delay is influenced by the length of the cable through which the data packet passes. However, the delay is not as great as when using wireless. This is because delay cannot be influenced by walls. It can be seen that the delay of both can be affected by the weather. Delay can cause the heart signal graph to be inaccurate with the simulator.

Packet Loss Calculation Analysis

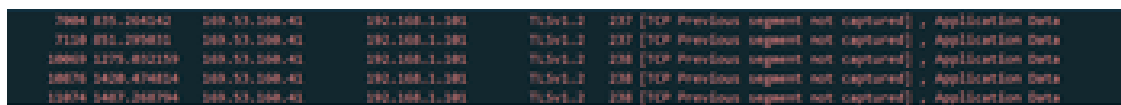

Figure 21 Capture Data Packet Loss on Wireshark Software

Packet loss can be defined as a failure in transmitting data packets to their destination address. Thus causing some packets in the delivery time to be lost (lost). This is caused by a number of factors such as signal degradation in the network medium, exceeding the network saturation limit, corrupt packets refusing to transit, and network hardware errors can be used as factors. Some network transport protocols such as TCP provide packet delivery, the receiver will request retransmission or delivery automatically

(resends) even though the segment has been acknowledged. Therefore, to obtain packet loss, testing is carried out using wireshark software, so that packet loss parameters are obtained in data retrieval. As shown in Figure 21.

Table 3 Packet Loss Category Index

Media Transmission	Testing Time	Package sent (bytes)	Pack-age received	Pac-ket Loss (%)	In-dex	Cate-gories
UTP	30 minutes	12682	12676	0.4	4	Excellent
	1 hours	26857	26846	0.04	4	Excellent
	2 hours	56947	56937	0.01	4	Excellent
	5 hours	780732	778317	0.30	4	Excellent
	8 hours 6 minutes	356207	355298	0.25	4	Excellent
	12 hours	804337	801513	0.35	4	Excellent
	18 hours	304593	301755	0.93	4	Excellent
	23 hours 34 minutes	3233010	3226164	0.21	4	Excellent
	Wire-less	30 minutes	37966	37637	0.86	4
1 hours		29675	2964	0.09	4	Excellent
2 hours		40325	40296	0.07	4	Excellent
5 hours		122659	122396	0.21	4	Excellent
8 hours 27 minutes		276711	275933	0.28	4	Excellent
12 hours 7 minutes		567264	566401	0.15	4	Excellent
18 hours		514742	513964	0.15	4	Excellent
22 hours 6 minutes		675905	671385	0.66	4	Excellent

When data transmission takes place, it will produce packet loss with values in each test, namely 0.25%; 0.35%; 0.21%; 0.28%; 0.15%; and 0.66%. which indicates that when sending and receiving data (transmission) is broken or lost. This can occur due to packet loss, when requesting or receiving data or from the server experiencing network failure, traffic congestion in the network, hardware errors used such as laptops due to application background updates, and limited bandwidth on the internet network when transmitting data to the server or receiving data from the server to the client.

Throughput Calculation Analysis



Figure 22 Capture Data Throughput on Wireshark Software

Throughput is a measurable network performance. Throughput is also defined as the ability in a network when sending data per unit time. To get throughput, testing is carried out using wireshark software so that the throughput parameters contained in the data collection are obtained as shown in Figure 22.

Table 4 Throughput Category Index

Media Transmission	Testing time	Throughput (bit/s)	Index	Throughput Categories
UTP	30 minutes	8	1	Bad
	1 hours	11	1	Bad
	2 hours	11	1	Bad
	5 hours	248	4	Excellent
	8 hours 6 minutes	45	2	Average
	12 hours	120	4	Excellent
	18 hours	15	1	Bad
Wireless	23 hours 34 minutes	241	4	Excellent
	30 minutes	115	4	Excellent
	1 hours	20	1	Bad
	2 hours	13	1	Bad
	5 hours	17	1	Bad
	8 hours 27 minutes	47.243	2	Average
	12 hours 7 minutes	66	3	Good

Media Trans-mission	Testing time	Throughput (bit/s)	Index	Throughput Categories
	18 hours	24	1	Bad
	22 hours 6 minutes	66	3	Good

5. CONCLUSION AND CLOSURE

Conclusion

After testing the human heart rate monitoring tool by utilizing the IoT-based ECG module, it can be concluded that the tool is *portable* which has a battery with a capacity of 3000mAh that can be carried anywhere and anytime. However, the tool has limitations, namely if used with the internet, it must have an internet network with a large and stable *bandwidth*. If it does not have a stable internet network, it is certain that the QoS value is very bad. But there are other alternatives to overcome this, namely if not connected to the internet, you can use *offline* mode which can take measurements without the internet. Then, the measurement data is stored in the *SD card*. If you want to display the data, you can use an *SD card reader* and convert it into a graph in *Microsoft Excel*.

Closure

In completing this final project, there are still many shortcomings and weaknesses from the author. So that if there will be further research, the author suggests that the recorded heart rate uses the real heart rate and has a *bandwidth* capacity of 100 mbp

BIBLIOGRAPHY

- Hasibuan, D. K., & Mulyadi, I. H. (2018). Real-Time Heart Rate Monitoring for Wearable Electrocardiography Using Filter-Based and Peak Threshold Algorithms: A Comparative Study. *Jurnal Integrasi*, 10(2), 54–58. <https://doi.org/10.30871/ji.v10i2.983>
- Madona, P., & Fadilla, R. (2021). *Akuisisi Sinyal Electrocardiography (ECG) Berbasis Arduino*. 7(1), 35–46.
- Nadia, I. (2018). *Kematian Mendadak karena Serangan Jantung*. Emc Health Care. <https://www.emc.id/id/care-plus/kematian-mendadak-karena-serangan-jantung>
- Nurfiqin, L. (2020). Analisis Quality Of Service (QoS) Protokol MQTT dan HTTP Pada Sistem Smart Metering Arus Listrik. *Jurnal Repositor*, 3(1). <https://doi.org/10.22219/repositor.v3i1.1084>

- Pan, J., & Tompkins, W. J. (1985). A Real-Time QRS Detection Algorithm. *IEEE Transactions on Biomedical Engineering, BME-32*(3), 230–236. <https://doi.org/10.1109/TBME.1985.325532>
- Ponikowski, P., Anker, S. D., AlHabib, K. F., Cowie, M. R., Force, T. L., Hu, S., Jaarsma, T., Krum, H., Rastogi, V., Rohde, L. E., Samal, U. C., Shimokawa, H., Budi Siswanto, B., Sliwa, K., & Filippatos, G. (2014). Heart failure: Preventing disease and death worldwide. *ESC Heart Failure, 1*(1), 4–25. <https://doi.org/10.1002/ehf2.12005>
- Ria Hariri, R. H., Lutfi Hakim, L. H., & Riska Fita Lestari, R. F. L. (2020a). Sistem Monitoring Detak Jantung Menggunakan Sensor AD8232. *JOURNAL ZETROEM, 2*(2). <https://doi.org/10.36526/ztr.v2i2.1017>
- Ria Hariri, R. H., Lutfi Hakim, L. H., & Riska Fita Lestari, R. F. L. (2020b). Sistem Monitoring Detak Jantung Menggunakan Sensor AD8232. *Journal Zetroem, 2*(2), 1–5. <https://doi.org/10.36526/ztr.v2i2.1017>
- Saputra, G. Y., Afrizal, A. D., Mahfud, F. K. R., Pribadi, F. A., & Pamungkas, F. J. (2017). Penerapan Protokol MQTT Pada Teknologi Wan (Studi Kasus Sistem Parkir Univeristas Brawijaya). *Informatika Mulawarman : Jurnal Ilmiah Ilmu Komputer, 12*(2), 69. <https://doi.org/10.30872/jim.v12i2.653>
- Sarmah, S. S. (2020). An Efficient IoT-Based Patient Monitoring and Heart Disease Prediction System Using Deep Learning Modified Neural Network. *IEEE Access, 8*, 135784–135797. <https://doi.org/10.1109/ACCESS.2020.3007561>
- Toldinas, J., Lozinskis, B., Baranauskas, E., & Dobrovolskis, A. (2019). MQTT Quality of Service versus Energy Consumption. *2019 23rd International Conference Electronics, 1–4*. <https://doi.org/10.1109/ELECTRONICS.2019.8765692>
- Wohingati, G. W., & Subari, A. (2015). ALAT PENGUKUR DETAK JANTUNG MENGGUNAKAN PULSESENSOR BERBASIS ARDUINO UNO R3 YANG DIINTEGRASIKAN DENGAN BLUETOOTH. *Gema Teknologi, 17*(2). <https://doi.org/10.14710/gt.v17i2.8919>